

Always “On” UPS Systems Inc.

GES L-Series – Single Phase Input, Single Phase Output



Uninterruptible Power Supply USER MANUAL

Version 1.4

GES-801L, GES-102L, GES-152L, GES-202L, GES-302L

Line Interactive (True Sine Wave):

800VA, 1000VA, 1500VA, 2000VA, 3000VA

*Extended Run-Time Battery Banks
Available on All Models*

Always “On” UPS Systems Inc.

SAVE THESE INSTRUCTIONS

- ✧ This manual contains important instructions for the GES-801L, GES-102L, GES-152L, GES-202L, GES-302L and should be followed during installation and maintenance of the UPS and batteries.
- ✧ The UPS contains voltages that are potentially hazardous. Please contact our dealers or qualified personnel for service.
- ✧ Servicing of the batteries should be performed or supervised by personnel knowledgeable with batteries and the required precautions. Keep unauthorized personnel away from batteries.
- ✧ When replacing batteries, replace with the same model number, type and rating.
- ✧ **CAUTION:** Do not dispose of the batteries in a fire. The batteries may explode.
- ✧ **CAUTION:** Do not open or mutilate the batteries. Released electrolyte is harmful to the skin and eyes. It may be toxic.
- ✧ **CAUTION:** A battery can present a risk of electrical shock and high short circuit current. The following precautions should be observed when working on or with the batteries.
 - Remove watches, rings, or other metal objects.
 - Use tools with insulated handles.
 - Wear rubber gloves and boots.
 - Do not lay tools or metal parts on top of batteries.
 - Disconnect charging source prior to connecting or disconnecting battery terminals.
 - Determine if the batteries are inadvertently grounded. If inadvertently grounded, remove source of ground. Contact with any part of a grounded battery can result in electric shock. The likelihood of a shock will be reduced if grounds are removed during installation and maintenance (applicable to a UPS and a remote battery supply not having a grounded supply circuit).
- ✧ **CAUTION:** To ensure the safety and performance of the UPS, never load the UPS with a hair dryer, heater, laser printer, Surge protector or other types of inductive loads.

Always “On” UPS Systems Inc.

TABLE OF CONTENTS

INTRODUCTION	5
SAFETY INSTRUCTIONS	6
PRESENTATION	7
FRONT PANEL	7
REAR PANEL	8
INSTALLATION	10
UNPACKING AND INSPECTION	10
PLACEMENT	10
CONNECT COMPUTER INTERFACE (OPTIONAL)	10
CONNECT EXTERNAL BATTERY BANK (OPTIONAL)	10
CONNECT TO UTILITY	10
CHARGING THE BATTERY	10
CONNECTING THE LOADS	10
CONNECTING THE TELEPHONE/MODEM/ETHERNET LINES	11
CHECK THE SITE WIRING FAULT INDICATOR	11
OPERATION	12
SWITCHING “ON” THE UPS	12
SWITCHING “OFF” THE UPS	12
SELF-TEST	12
SILENCE THE ALARM	12
LOAD BAR GRAPH	12
BATTERY CHARGE BAR GRAPH	13
COLD START	13
SHUTDOWN MODE	13
AUDIBLE ALARM	13
BACK-UP (SLOW ALARM)	13
LOW BATTERY (RAPID ALARM)	13
OVERLOAD (CONTINUOUS ALARM)	13
REPLACE BATTERY (CONTINUOUS ALARM)	13
SOFTWARE OPTIONS	14
UPSILON 2000 SOFTWARE	14
INTERFACE KITS	14
COMPUTER INTERFACE PORT	15
<i>Open Collector (Dry Contact) Communication</i>	15
<i>RS-232 Communication</i>	15
BATTERY REPLACEMENT	16
TROUBLESHOOTING	17
STORAGE	18
STORAGE CONDITIONS	18
EXTENDED STORAGE	18
BATTERY BANK INSTALLATION	19
SPECIFICATIONS	20
CONTACT INFORMATION	22
ADDITIONAL PURCHASES OR UPGRADES	22
QA / WARRANTY QUESTIONS	22
SOFTWARE QUESTIONS	22

Always “On” UPS Systems Inc.

Introduction

The L-Series is a Line Interactive UPS system that includes the newest and latest technology enhancements. The Line Interactive technology with AVR function (on-line voltage boost-up & buck-down) allows for a wide input voltage range of 90 to 150VAC. The L-Series UPS is the ideal protection for microprocessor controlled loads. With the utility power connected, the charger begins to operate immediately, charging the battery. In the event of a blackout (or severe brownout) the UPS will automatically switch to back-up mode and maintain power to the load until the software shuts down the system and/or when the battery reaches a low voltage state. The Low Battery indicator will turn “On” if and when the battery needs replacement. Also included, with our UPS systems, is a cyclic self-testing function to verify both the operation of the UPS and the condition of the battery.

In addition, the L-Series UPS provides advanced telephone line and Ethernet surge suppression through the modular connectors on the back panel.

The Line Interactive UPS in conjunction with our monitoring software makes your UPS operate intelligently and provides you with total protection for all your loads.

Note: Interference to radio/TV might occur in a particular installation. If this UPS causes interference to radio or television reception, which can be determined by turning the UPS off and on, the user is encouraged to try to correct the interference by one or more of following measures:

- 1. Connect the equipment to an outlet on a circuit different from that to which the receiver is connected.*
- 2. Increase the separation between the equipment and the receiver.*
- 3. Reorientate the receiving antenna.*

Safety Instructions

The UPS has its own internal energy source (batteries), therefore the output receptacles may have electricity present even though the UPS is disconnected from the utility power.

The DC voltage provided from the internal batteries are as follows:

- | | | | | | |
|----|----------|-------|----|----------|-------|
| a) | GES-801L | 24VDC | d) | GES-202L | 48VDC |
| b) | GES-102L | 24VDC | e) | GES-302L | 48VDC |
| c) | GES-152L | 36VDC | | | |

Isolated Ground Wire refers to the bare wire connecting electrical equipment to ground. The isolated ground wire (green or green with yellow stripe) must meet national wire requirements.

The power plug to connect with the UPS has to be equipped with a ground plug.

The batteries must be replaced or serviced by qualified, knowledgeable, personnel.

Replacement batteries must be the same type, quantity and configuration as the originals.

To avoid explosions, keep open flame and other heat emitting sources away from batteries.

Do not disassemble or damage the batteries. The electrolyte is toxic and especially harmful to the eyes and skin.

The batteries contain high voltages and currents that are dangerous. To maintain secure operation and performance of the UPS, the user must exercise basic and regular maintenance.

Please follow the precautions below:

1. Do not remove the UPS cover unless authorized by factory. Removing the cover will void the warranty.
2. The UPS can only be connected to a 2-pole/3 wire plug.
3. Do not install the UPS in an environment with excessive humidity.
4. Do not allow liquids or foreign objects to get inside the UPS.
5. Allow for air circulation through the UPS. A minimum clearance of 10 cm is required on all sides.
6. Do not load the UPS with appliances such as a hair dryer, heater, vacuum, kettle, etc.
7. Keep the UPS away from direct sunlight and heat-emitting sources.
8. Install the UPS as close as possible to the load for maximum protection.
9. Storage Requirements
 - a. Recharge the UPS batteries every 6 months for no less than 8 hours at a time.
 - b. Under a high ambient temperature environment, recharge the UPS batteries every 3 months for no less than 8 hours at a time
10. High Voltage Risk:
 - a. High voltages might exist between the battery terminal and the grounding system, if the battery circuit has not been disconnected from the UPS circuit. Please check this voltage before connecting.
 - b. Disconnect the battery wires before proceeding with maintenance. High voltages may be present between the UPS internal components and batteries even after the input power is disconnected.

Presentation

Front Panel

1. POWER bar graph (BATTERY CHARGE/LINE VOLTAGE)

This displays the present battery charge as a percentage of battery capacity. It also displays the utility line voltage.

2. LOAD bar graph

This displays the amount of power required by the load as a percentage.

3. "OVERLOAD" indicator (RED LED)

This LED lights when the load(s) connected to the UPS exceed the UPS's capacity. See Section 6.3 for solution to this problem.

4. "BUCK AVR (Automatic Voltage Regulation)" indicator (YELLOW LED)

This LED illuminates when the UPS is correcting for a high utility voltage condition. The load(s) receive normal 120VAC power.

5. "ON/TEST" button

With the UPS plugged in, press the ON/TEST button to turn on the UPS and power the loads. ON/TEST also activates the UPS's self-test and utility line voltage displays.

6. "LINE NORMAL" indicator (GREEN LED)

This LED illuminates when the line input voltage is normal.

7. "OFF" button

Press the OFF button to turn off the UPS and the load(s).

8. "BACK UP" indicator (GREEN LED)

This LED illuminates when the UPS is supplying battery power to the loads.

9. "BOOST AVR (VOLTAGE BOOST)" indicator (YELLOW LED)

The LED illuminates when the UPS is correcting for a low utility voltage condition. The load(s) receive normal power.

10. "REPLACE BATTERY" indicator (RED LED)

This LED illuminates when the UPS's batteries are no longer useful and must be replaced.

Note: When replacing the batteries, disconnect the utility power then open the case. Take notice of the polarity before installing the new batteries to avoid a short.

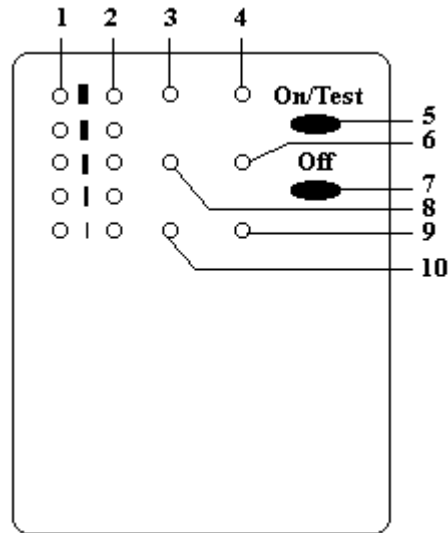

Rear Panel

11. TELEPHONE/MODEM/ETHERNET SURGE PROTECTION

Surge protection for telephone line, modem line, and 10BaseT line to maintain a completely safe connection for INTERNET/INTRANET service.

12. EXTERNAL BATTERY PACK CONNECTOR (optional)

Allows for extended runtime.

Caution: Use only factory supplied or authorized connecting cable for external battery pack!

13. SNMP INTERFACE PORT (optional)

This option will allow the UPS to be connected directly to a network and also allow for remote monitoring. Through the RS-232 communication port, the SNMP adapter makes your UPS become "SNMP manageable", and provides real time UPS and power status information for the network manager.

Note: It's not necessary to use this option.

Caution: Use only factory supplied or authorized SNMP monitoring kit.

14. OUTPUT POWER RECEPTACLES

Connect load(s) here.

15. AC INPUT POWER RECEPTACLE

Plug into properly rated outlet.

Always “On” UPS Systems Inc.

16. INPUT CIRCUIT BREAKER

It trips when the connected loads exceed the protected receptacle's capacity. The center plungers of the circuit breakers extend when tripped.

17. SITE WIRING FAULT INDICATORS (RED LED)

It illuminates when the UPS is connected to an improperly wired AC power outlet.

Note: This device is available on 120 VAC model only.

18. COMPUTER INTERFACE

Provides both RS-232 and relay signal to support NOVELL, UNIX, DOS, WINDOWS and other operating systems.

Always “On” UPS Systems Inc.

Installation

Unpacking and Inspection

Examine the packaging for damage. Inform the carrier immediately if and/or when damage is noticed. Retain the packaging for future use.

Placement

Install the UPS in a protected area with adequate airflow and free of excessive dust. Do not operate the UPS where the temperature and humidity is outside the specified limits.

Connect Computer Interface (optional)

UPSilon 2000 (or selected option) and an interface kit can be used with this UPS. Use only kits supplied or approved by the manufacturer. If used, connect the interface cable to the 9 pin computer interface port on the back panel of the UPS (See Back Panel).

Note: Computer interface connection is optional. The UPS works properly without a computer interface connection.

Connect External Battery Bank (optional)

Before connecting, make sure the external battery bank and the connector cable are compatible with this UPS.

Note: External battery connection is not necessary. The UPS will work properly without an external battery bank connection.

Caution: Use only factory supplied external battery connection cables!

Connect to Utility

Connect the AC input power connector (included) to utility power.

Charging the Battery

The UPS charges its battery whenever it is connected to utility power. For best results, charge the battery for 4 hours initially before connecting the load.

Connecting the Loads

Plug the loads into the output connectors on the rear of the UPS. To use the UPS as a master on/off switch, make sure all of the loads plugged into the UPS are switched on. Also available on these models is a surge-protected outlet where you can plug in your laser printer, plotter, etc.

Note: Never connect a laser printer or plotter to a backup outlet with other computer equipment. A laser printer or plotter draws significantly more power on start-up than when idle, and will overload the UPS. If you wish to have battery backup on a laser printer or plotter you will need to increase the size of the UPS system.

Always “On” UPS Systems Inc.

Connecting the Telephone/Modem/Ethernet Lines

Connect a telephone line, modem line, or 10BaseT line into the telephone/modem/Ethernet surge protection sockets on the back of the UPS. The RJ-45/RJ-11 modular sockets accept standard single line telephone connections and 10BaseT connectors. This connection will require another length cable.

Note: This connection is optional. It is not necessary to use this with the UPS.

Caution: The line current limiting feature could be rendered inoperable if improperly installed. Make sure that the line from the wall is plugged into the connector marked “IN”, and the device to be protected (telephone, modem, etc.) is plugged into the connector marked “OUT”.

Caution: This surge protection device is for indoor use only, never install wiring during a lightning storm.

Check the Site Wiring Fault Indicator

After plugging in the load(s) and the UPS, check the site wiring fault indicator on the rear panel. It lights up if the UPS is plugged into an improperly wired AC power outlet. Wiring faults detected include ground, hot-neutral polarity reversal, and overloaded neutral circuit.

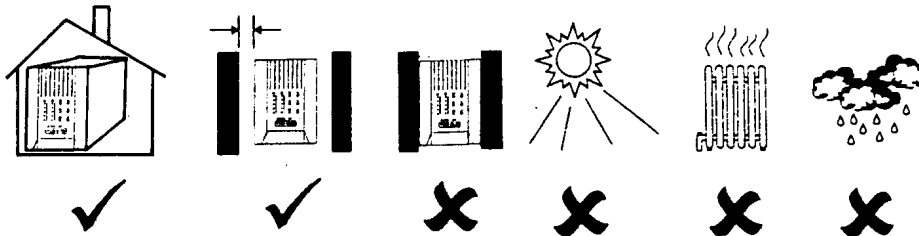

Always “On” UPS Systems Inc.

Operation

Switching “On” the UPS

With the UPS plugged in, press and hold the “ON/TEST” button for at least 1 second to switch the UPS on. The UPS will perform a self-test each time it is switched on.

Note: When switched off, and still plugged into utility, the UPS maintains the battery charge and will respond to commands received through the computer interface port.

Switching “Off” the UPS

Press and hold the “OFF” button until the "LINE NORMAL" or "BACK UP" LED turns off. To fully turn off UPS also unplug the utility cord from the UPS.

Self-test

The self-test verifies that both the operation of the UPS and the condition of the batteries are normal. Under normal operating power, push and hold the ON/TEST button for more than 1 second and the UPS will perform a self-test function. During the self-test, the UPS will operate in back-up mode.

Note: During the self-test, the UPS briefly operates the load(s) on battery power (the Back-Up LED turns on). If the UPS passes the self-test, it returns to on-line operation the Back-Up LED turns off and the Line Normal LED turns on steady. If the UPS fails the self-test it immediately returns to normal operation and the Replace Battery LED turns on. The loads are unaffected by the self-test. Recharge the battery overnight and perform the self-test again. If the Replace Battery LED is still on, ask our nearest dealer about replacing the batteries.

Silence The Alarm

In "Back-Up" mode, push and hold the “ON/TEST” button for more than 1 second to silence the audible alarm. This function is unavailable under "LOW BATTERY" or "Overload" conditions.

Note: In Back-Up mode, the UPS can be automatically turned off if none of the connected loads are operating.

Load Bar Graph

This 5 LED display shows the power required by the load as a percentage of the UPS's rated capacity. For example: If three LEDs are lit, the load is drawing between 50% and 67% of the total capacity. If the UPS is overloaded, the overload LED lights and an alarm sounds.

Always “On” UPS Systems Inc.

Battery Charge Bar Graph

This 5 LED display indicates the present charge of the UPS's batteries as a percentage of the total battery capacity. When all five LED's are lit, the batteries are fully charged. When only two of the LED's are lit, the batteries can supply less than two minutes of power to the load.

Cold Start

When the UPS is off, and there is no utility power, use the cold start feature to apply power to the loads from the UPS's battery. Press and hold the “ON/TEST” button until the UPS beeps.

Shutdown Mode

In shutdown mode the UPS stops supplying power to the load, and waits for the return of utility power. If there is no utility power present, external devices (e.g., servers) connected to the computer interface port can command the UPS to shutdown. This is normally done to preserve battery capacity. The UPS will scroll the front panel indicators sequentially in shutdown mode.

Audible Alarm

Back-Up (Slow Alarm)

When in back-up mode, the Yellow LED illuminates and the UPS sounds an audible alarm. The alarm stops when the UPS returns to line normal operation. Press the On/Off/Test/Silence Button during back-up mode to silence the beeping.

Low Battery (Rapid Alarm)

In back-up mode, when the battery energy runs low, the UPS beeps rapidly until the UPS shuts down from battery exhaustion or returns to line normal operation.

Overload (Continuous Alarm)

When the UPS is overloaded (the connected load exceeds the maximum rated capacity of the UPS) the UPS sounds a continuous alarm to warn of an overload condition. Disconnect non-essential loads until the UPS stop the alarm, this will eliminate the overload.

Replace Battery (Continuous Alarm)

The UPS emits continuous beeps and the REPLACE BATTERY LED illuminates if the battery fails the self-test. See replace battery section for battery replacement or call your dealer for service.

Software Options

UPSilon 2000 Software

The UPSilon 2000 software utilizes standard RS-232 interface to perform monitoring functions, and provides an orderly shutdown of a computer system in the event of power failure. Moreover, UPSilon 2000 displays all the diagnostic symptoms through a graphical interface, such as Voltage, Frequency, Battery Level, etc.

The software is available for DOS, Windows 3.x, Windows 95/98/00 & Windows NT V3.5 or later, FreeBSD, Linex, Novell and more.

Interface Kits

A series of interface kits are available for various operating systems that provide UPS monitoring. Each interface kit includes the special interface cable required to convert status signals from the UPS into signals that the individual operating system will recognize. The interface cable at the UPS side must be connected to the REMOTE PORT, at the computer side it can be connected to either COM1 or COM2. For other installation instructions and powerful features please refer to READ ME file included within the software.

Caution: Use only factory supplied or authorized UPS monitoring kits!

Always “On” UPS Systems Inc.

Computer Interface Port

The computer interface port has the following characteristics:

The communication port on the back of the UPS may be connected to a host computer. This port allows the computer to monitor the status of the UPS and control the operation of the UPS. Its major functions include the following:

1. The ability to broadcast a warning when the power fails.
2. The ability to close any open files before the battery reserves are exhausted.
3. The ability to turn off the UPS.
4. The ability to make the UPS perform a self-test.

Some computers are equipped with a serial connector to link with the communication port, in some cases a special plug-in card may be needed.

Open Collector (Dry Contact) Communication

1. Pin 5 and 2 are open collector outputs that must be pulled up to a common referenced supply no greater than +40VDC.
2. The transistors are capable of a maximum non-conductive load of 25mADC, use pin 4 as the common.
3. Pin 5 generates a High to Low signal when the battery inside the UPS has less than 5 minutes back up time left.
4. Pin 2 generates a High to Low signal when the line has failed.
5. Pin 6 will shut down the UPS if a high is sustained for 0.36 seconds.

RS-232 Communication

6. Pin 6 is the RS-232 data input from computer (RX)
7. Pin 9 is the RS-232 data output to computer (TX).
8. Pin 7 is the common or computer ground

NOTE:

1. Switch rating +40V, 25mADC non-inductive.
2. Pin 7 should be connected to computer ground only.

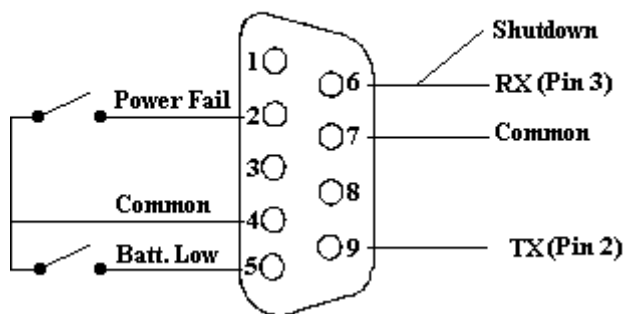

Battery Replacement

Your batteries should run anywhere from 3-5 years before they need to be replaced.

Please follow the instructions below for easy, trouble free, battery replacement.

1. Turn the UPS off (follow procedure previously mentioned)
2. Unplug the UPS from utility power source and disconnect all connected loads.
3. Disconnect AC power cord from unit.
4. Using a phillips screw driver, unscrew the screws holding the top of the unit to the bottom. Put screws in a safe place for reconnection.
5. Carefully lift top cover off and place it to the side. The connecting wires and electronics will be exposed. **Be careful not to touch any inner components when changing the battery.**
6. Remove the two (2) main connecting wires (the Red and Black ones) from the batteries.
7. You can now easily remove the batteries from the unit

Caution: Do not dispose of the batteries in a fire.

Caution: Do not attempt to open the batteries.

Caution: The following precautions should be taken when replacing the batteries

- a) **Remove watches, rings, etc.**
 - b) **Use tools with insulated handles**
8. Place your new batteries in the same position, direction and reconnect the wires. The red wire to the positive (+) pole and black wire to the negative (-) pole.
 9. Please reverse steps 5, 4 and 3 (in that order) to reassemble the unit.
 10. Follow the start-up instructions to properly reconnect your equipment.

Always “On” UPS Systems Inc.

Troubleshooting

Please follow the guidelines below for solutions to common problems:

- ✓ Check UPS input plug and wiring.
- ✓ Check UPS input voltage.

Please prepare the information as follows for service personnel:

- ✓ UPS model number and serial number
- ✓ Description of problem(s) in detail.

General Problems

Problems	Possible causes	Solution
UPS has no reaction while AC power is connected	Fuse/Breaker at back panel open No AC input UPS fault Battery failure	Replace Fuse/Switch breaker on Check AC power Call for service Call service center to replace batteries
UPS no reaction while AC power is connected, yet starts after pushing power on/off switch	Breaker at back panel blown No AC input UPS AC detecting circuit fail	Switch breaker Check AC power Call for service
UPS goes into back-up mode while connected to AC power	Utility voltage or frequency abnormal UPS AC detecting circuit failure	Check AC power Call for service
Fault LED lit	Inverter fault. Over temperature Battery over voltage. DC bus fault. Overload fault.	Call for service Check load situation
Battery can not provide normal back-up power in the event of a blackout	Battery deteriorated Batteries not fully charged Battery charger damaged	Charge batteries and reset If that doesn't work call for service
After AC connected to UPS, alarm sounds short and fast beeps and UPS shuts down	Abnormal utility power	Check input power

Storage

Storage Conditions

Store the UPS covered and upright in a cool, dry location, with its battery fully charged. Before storing, charge the UPS for at least eight (8) hours. Remove any accessories from the accessory slot and disconnect any cables connected to the computer interface port to avoid unnecessary drain on the battery.

Extended Storage

During extended storage periods in environments where the ambient temperature is -15 to +30°C (+5 to +86°F), charge the UPS's battery every 6 months.

During extended storage in environments where the ambient temperature is +30 to +45°C (+86 to +113°F), charge the UPS's battery every 3 months.

Battery Bank Installation

Install up to 8 battery banks per L Series UPS following the instructions below.

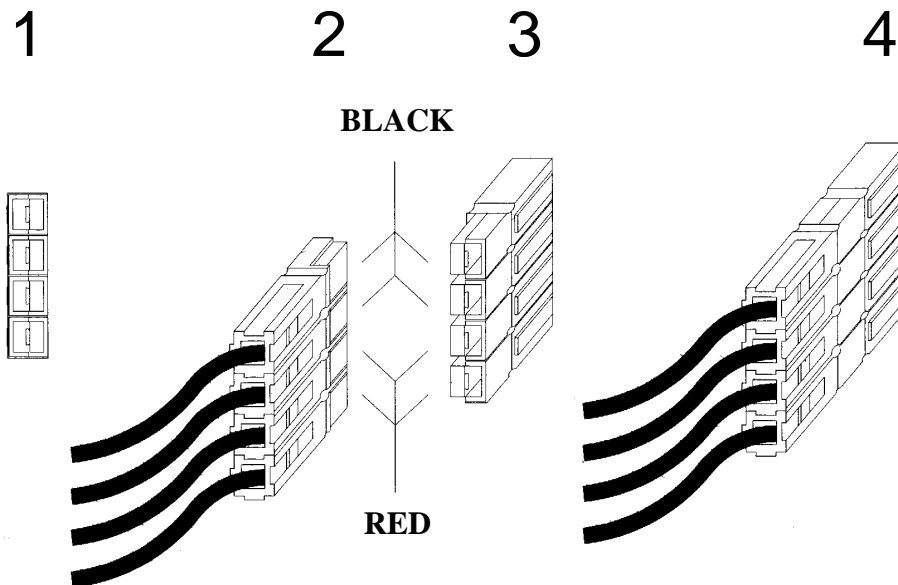

Caution: Make sure the UPS is shutdown and unplugged before connecting additional Battery Packs (refer to Switching the UPS “Off” section, page 11)

1. Locate the external battery connector located at the rear of the UPS.
2. Make sure you are connecting the connector correctly or problems will occur.
3. Insert the battery bank connector into the UPS.
4. The UPS is now ready to be turned on with extended runtime.

To install additional battery banks, repeat this procedure using the battery bank connectors on the back of the battery banks.

Note: Do not stack battery banks, and make sure proper polarity.

Always “On” UPS Systems Inc.

Specifications

Specification Comparison	MODEL NO.	GES-801L	GES-102L	GES-152L	GES-202L	GES-302L
GENERAL	MAXIMUM CAPACITY	800VA / 560W	1kVA / 700W	1.5kVA / 1050W	2kVA / 1400W	3kVA / 2100W
	UPC ORDER CODE	825433 22100	825433 22200	825433 22300	825433 22400	825433 22500
INPUT	NOMINAL VOLTAGE	120VAC (220 optional)				
	VOLTAGE RANGE	+ / - 25%				
	FREQUENCY RANGE	50 or 60 Hz auto-sensing + / - 5%				
OUTPUT	NOMINAL VOLTAGE	120VAC				
	AUTO VOLTAGE REGULATION	+15% for 90 - 109VAC; -15% for 130 - 150VAC				
	CURRENT	6.6A	8.33A	12.5A	16.6A	25A
	FREQUENCY	50Hz / 60Hz (Auto Detected) + / - 0.5%				
	POWER FACTOR	0.5 - 1.0				
	WAVE FORM (ON BATTERY)	TRUE SINE WAVE				
	LOAD CREST FACTOR	3:1 (ON BATTERY)				
	TRANSFER TIME	2 - 4ms (Typical), including detection time				
	OUTLETS	4	4	6	6	4 + Hardwired
BATTERY	BATTERY TYPE	SEALED LEAD ACID - MAINTENANCE FREE				
	QUANTITY	2	2	3	4	4x2
	VOLTAGE	24VDC	24VDC	36VDC	48VDC	48VDC
	RECHARGE TIME	≤ 2 to 4 Hours; Recovery = 90%, Typically				
BACKUP POWER TIME	FULL LOAD	≥ 8 MIN.	≥ 7 MIN.	≥ 7 MIN.	≥ 7 MIN.	≥ 8 MIN.
	HALF LOAD	≥ 20 MIN.	≥ 17 MIN.	≥ 25 MIN.	≥ 25 MIN.	≥ 25 MIN.
	PENTIUM & 17" MON	≥ 41 MIN.	≥ 41 MIN.	≥ 70 MIN.	≥ 75 MIN.	≥ 90 MIN.
EXTENDED RUN TIME		Available				

Always “On” UPS Systems Inc.

PROTECTION	OUTPUT SHORT	YES				
	ABNORMAL VOLTAGE	YES				
	MODEM OR NETWORK	SINGLE LINE (2 wire RJ11) / NETWORK (UTP, RJ45) COMPATIBLE JACKS				
	I/O NOISE PROTECTION	COMMON & NORMAL MODE NOISE SUPPRESSION				
	I/O SPIKE & TRANSIENT PROTECTION	YES				
INTERFACE	COMMUNICATION	RS 232 / DRY CONTACT (OPTIONAL SNMP OR AS400)				
	LED DISPLAY	NORMAL / BACKUP / LOW BATTERY / FAULT / CHECK BATTERY / BUCK / BOOST				
	AUDIBLE ALARMS	ON BATTERY, LOW BATTERY, OVERLOAD, FAULT				
ENVIRONMENT	OPERATING TEMPERATURE	0 - 40°C (32 - 104°F)				
	HUMIDITY	0 - 95% (NON-CONDENSING)				
	AUDIBLE NOISE	< 40 dBA AT 1 METER FROM UNIT				
SAFETY APPROVAL	SAFETY	cUL, UL1778, CSA C22.2				
	EMI / RFI	FCC CLASS B				
	SURGE / TRANSIENT	IEEE C62.41 CAT.A				
PHYSICAL DATA	UPS WxDxH mm (in.)	140x436x210 (5.5x17.2x8.3)		170x450x226 (6.7x17.7x8.9)		
	EXTERNAL BATTERY BANK (if applicable)	INTERNAL BATTERIES				170x450x226 (6.7x17.7x8.9)
	WEIGHT in kg (lbs)	14.5 (32)	15 (33)	25 (55.1)	30 (66.1)	46 (101.4) (including battery bank)
RACK-MOUNT MODELS	MODEL NO.	GES-801LR	GES-102LR	GES-152LR	GES-202LR	GES-302LR
	UPC Order Code	825433 22105	825433 22201	825433 22301	825433 22401	825433 22501
	WxDxH mm (in.)	483x381x89 (19x15x3.5) [2U]			483x381x133 (19x15x5.25) [3U]	483x381x178 (19x15x7) [4U]
	WEIGHT in kg (lbs)	18 (35.3)	20 (44)	26.1 (57.5)	28.4 (62.6)	46.4 (102.3)

CONTACT INFORMATION

Additional Purchases or Upgrades

Always “On” UPS Systems Inc.
Bldg 1 – 150 Campion Road,
Kelowna, BC, Canada, V1X 7S8
Phone: (250) 491-9777 Ext 451
Fax: (250) 491-9775
Email: sales@alwaysonups.com
Website: www.alwaysonups.com

QA / Warranty Questions

Always “On” UPS Systems Inc.
Bldg 1 – 150 Campion Road,
Kelowna, BC, Canada, V1X 7S8
Phone: (250) 491-9777 Ext 209
Fax: (250) 491-9775
Email: qa@alwaysonups.com
Website: www.alwaysonups.com

Software Questions

Always “On” UPS Systems Inc.
Bldg 1 – 150 Campion Road,
Kelowna, BC, Canada, V1X 7S8
Phone: (250) 491-9777 Ext 204
Fax: (250) 491-9775
Email: webmaster@alwaysonups.com
Website: www.alwaysonups.com